

SECTION A-A
SCALE 1:3

N.2 BUSSOLE OTN.
M6x8x9 SQ. DA STAMPO
(cod.2720213)

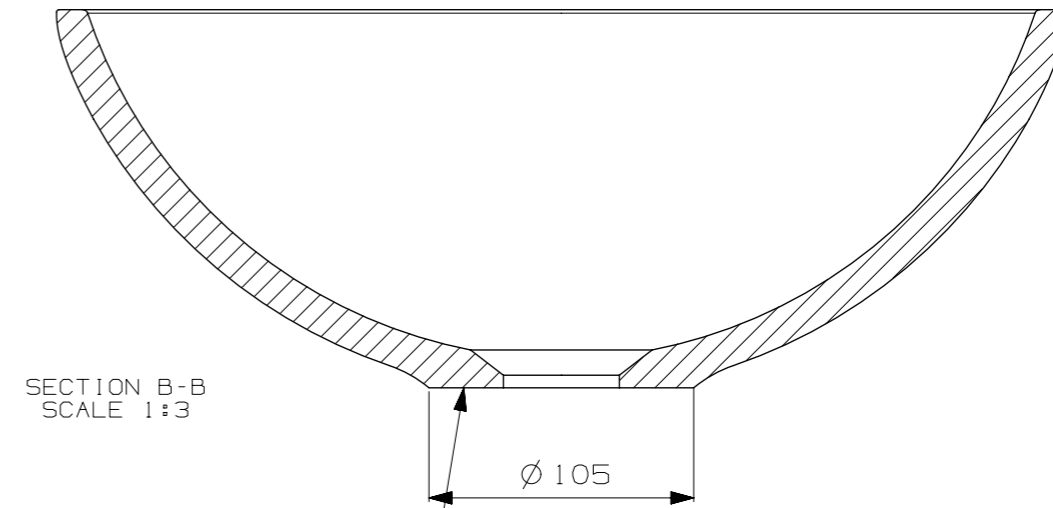

SECTION B-B
SCALE 1:3

ETICHETTA CSA "257127"
(cod.4070058)

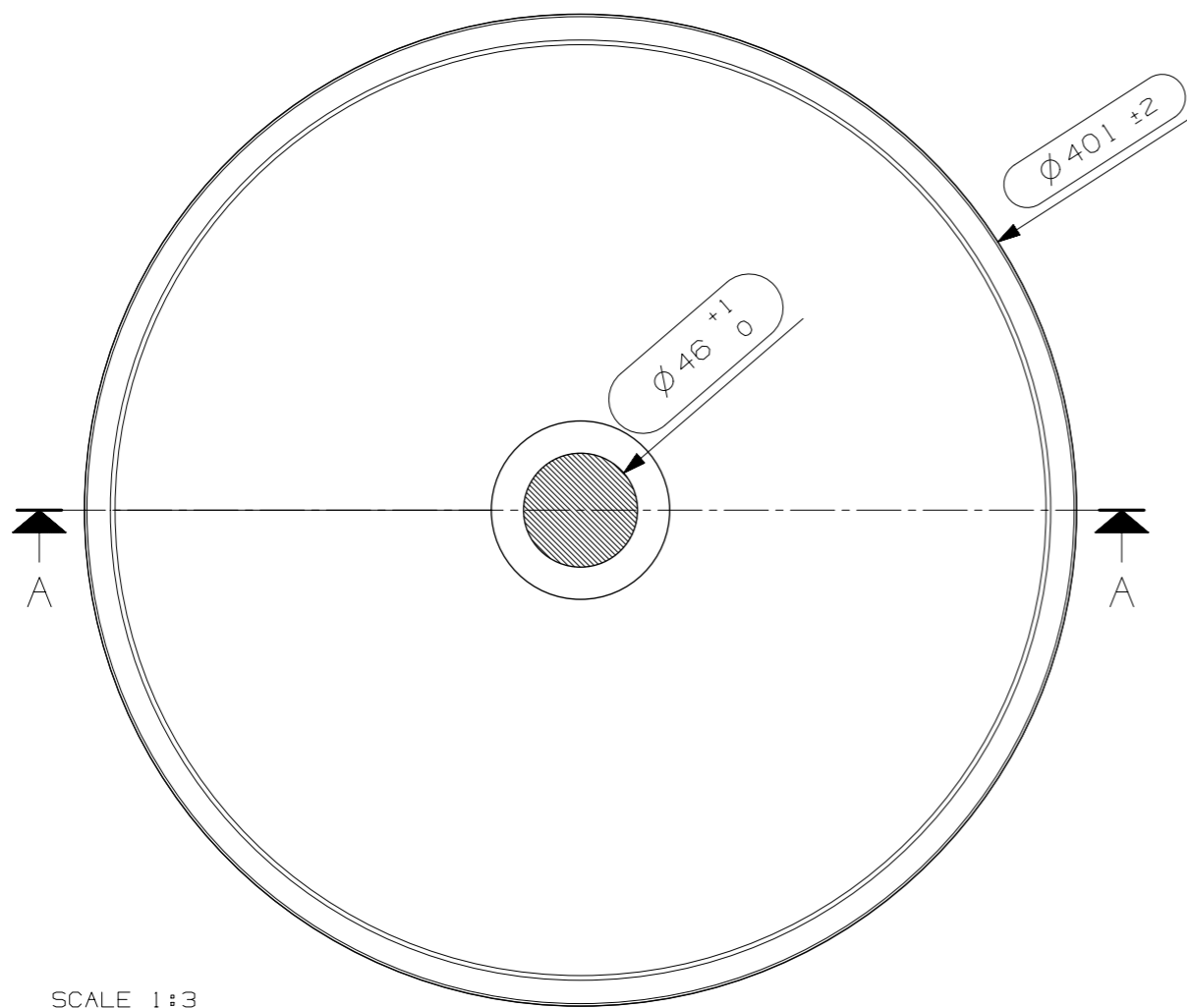

SCALE 1:3

- (KITFIS2) N° 1 KIT FISSAGGIO VASCHEE STD.CPL (2930077)
- N° 1 SACCHETTO NYLON MM.150x200 CONTENENTE
- (FOTOCO.) N° 1 FOGLIO ISTRUZIONI PER KITFIS2 -GRAFFARE INSIEME I DUE SACCHETTI-
- (FOTOCO.) N° 1 FOGLIO CURA E MANUTENZIONE MM

N°	DATA/Date	FIRMA/drawn by	DESCRIZIONE REVISIONE/Revision description
1			

NOTE/Notes		N° STAMPO/Mould Number
.....		M06951A
.....		PROG.10-278
.....		PESO NETTO/Weight
.....		Kg.5
.....		DATA REV.0/Date Rev.0
.....		12/12/2018
CLIENTE/Client	MODELLO/Model	EMESSO/Drawn by
NICOS	COSMOS	FABRIZIO D.
DENOMINAZIONE/Product Name		VERIFICATO/Checked by
LAVABO APPOGGIO TONDO		ANDREA M.
TUTTE LE QUOTE E TOLLERANZE INDICATE IN QUESTO DISEGNO SI RIFERISCONO A MISURAZIONI EFFETTUATE AD UNA TEMPERATURA DEL MANUFATTO DI 20°C +/-5°C.		PROIEZIONE/Projection
All the dimensions and the tolerances of this drawing are referred to mesurements taken with a temperature of the piece of 20°C +/-5°C.		